

REDI-LINER

Durable, Convenient, Affordable

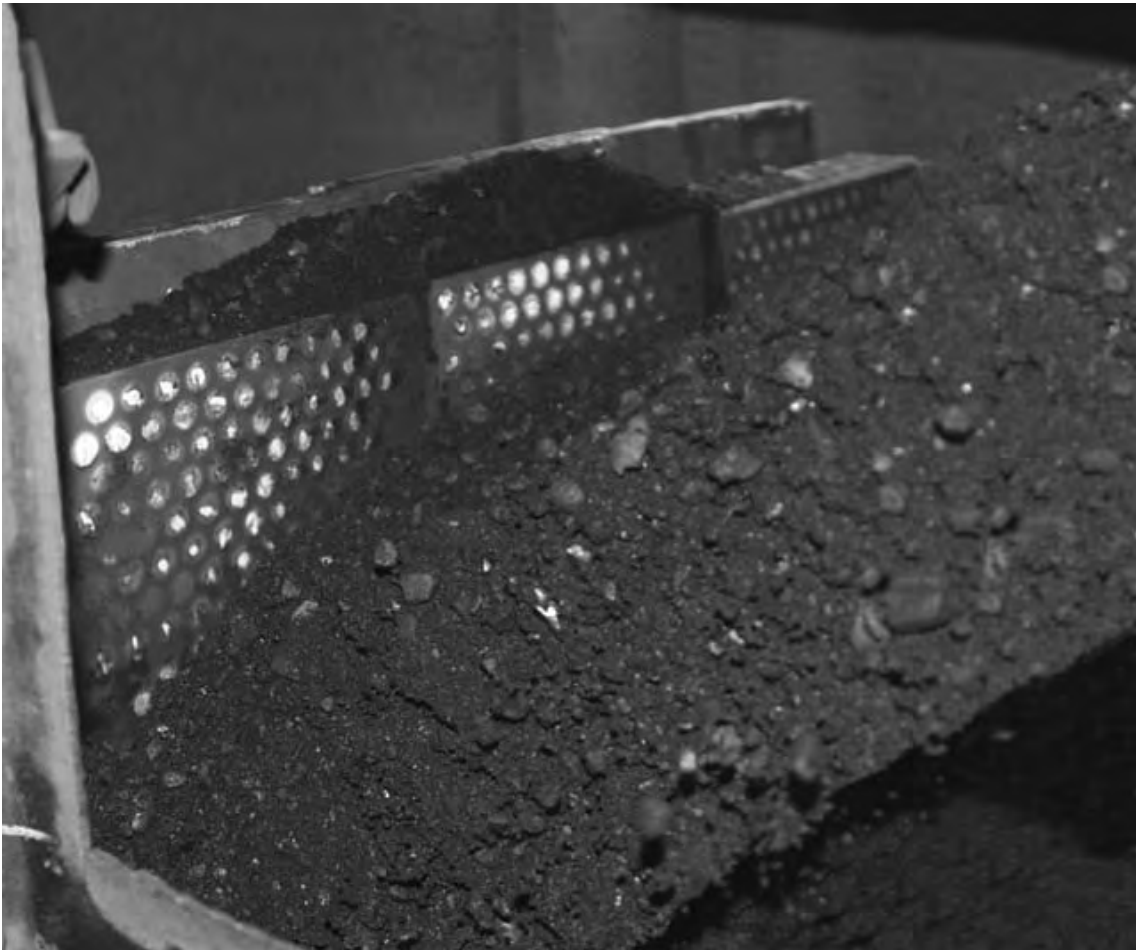

Modular Lining System



ARGONICS
ENGINEERED POLYURETHANE

⚠ WARNING ⚠

Always obey all applicable safety rules.

Be sure all power to the conveyor has been disconnected and controls are locked out.

Burning elastomers give off toxic fumes. Take extra time to minimize heat exposure. Have a fire extinguisher and a bucket of water with rags available at all times. If flames or smolders do occur, extinguish immediately. Use of forced air ventilation or an in-line respirator is strongly recommended.

Required tools and materials

- Tape measure
- Straight edge
- Scribe, grease pencil or marker
- 1/2" or 3/4" lock washers and nuts (one for each panel - not supplied)
- Drill
- 5/8" (16 mm) or 7/8" (22.5 mm) drill bit
- Wrench set

Optional tools and materials

- Level
- Loctite
- Bostik 1100 sealant

Lockwashers and nuts for mounting are not supplied

Torque Chart

Redi-Liner Stud	Do Not Exceed
1/2" diameter	60 ft. lbs of torque
3/4" diameter	150 ft. lbs of torque

Please Note:

1" thick Redi-Liner panels should only be used in sliding applications.

INSTALLATION

Step 1 - Getting Started

From the top of the chute measure down 6" (152 mm) and mark on each end of the chute. Then scribe a line connecting your marks across the entire width of the chute (figure 1).

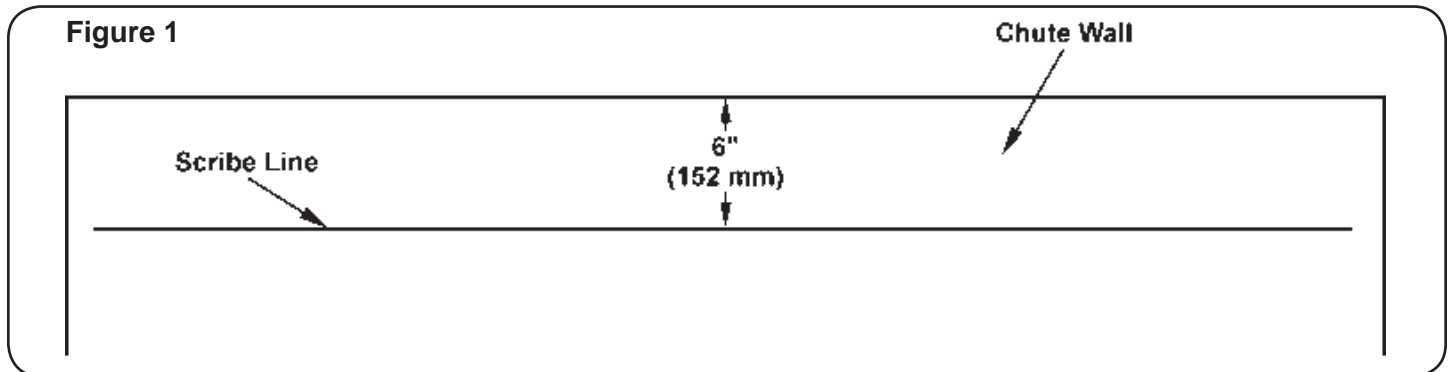

Step 2

Measure the width of the chute to find the center and mark its location on the scribed line you just made. This will be your first bolt hole location. Working to the sides, mark the remainder of the hole locations every 12" (305mm) (figure 2).

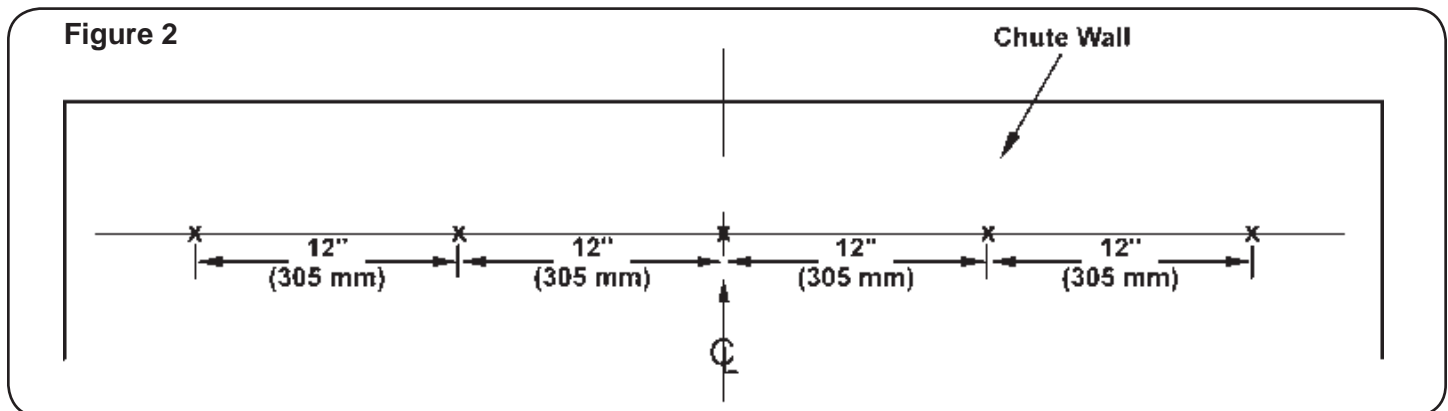

Step 3

Now drill holes for the Redi-Liner stud at each of your marked locations. Drill a $\frac{5}{8}$ " (16 mm) hole for the $\frac{1}{2}$ " stud or a $\frac{7}{8}$ " (22.5 mm) hole for the $\frac{3}{4}$ " stud.

Apply a small amount of Loctite (optional) to the supplied "all-thread" and thread by hand into the embedded nut located in the center of the back side of the Redi-Liner panel (figure 3).

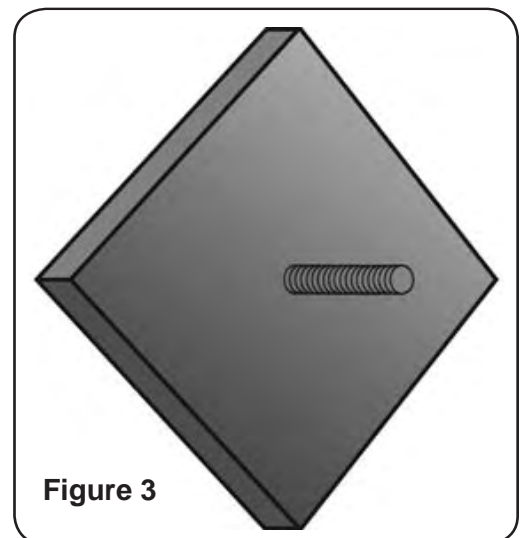

INSTALLATION

Step 6

Add a bead of Bostik to the bottom of the above course of panels and then repeat steps 3 through 6 until the chute is completely lined (figure 7).

You can cut the plain Redi-Liner panels to fit a tapered chute. Please keep in mind that there is a no-cut zone on the panel that is 6" (152 mm) in diameter around the stud (figure 8).

Figure 6 - Chute with 6" x 12" (152 x 305 mm) filler panels installed.

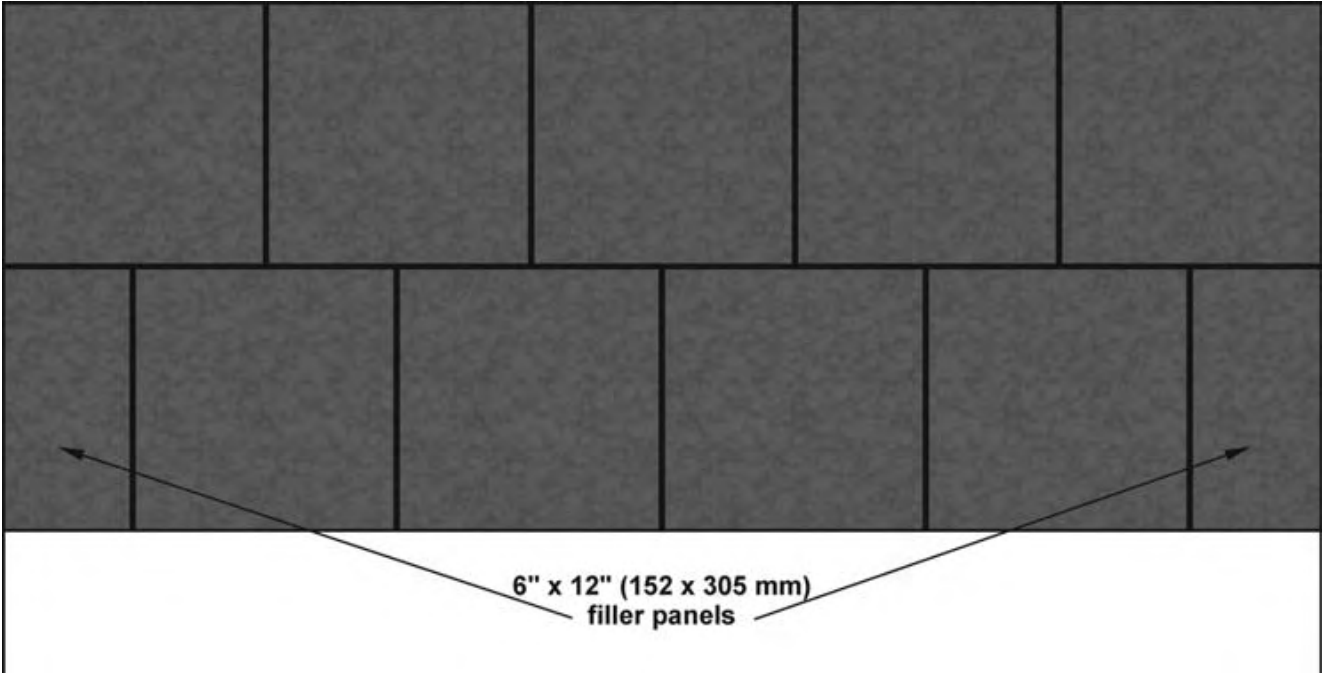

INSTALLATION

Figure 7

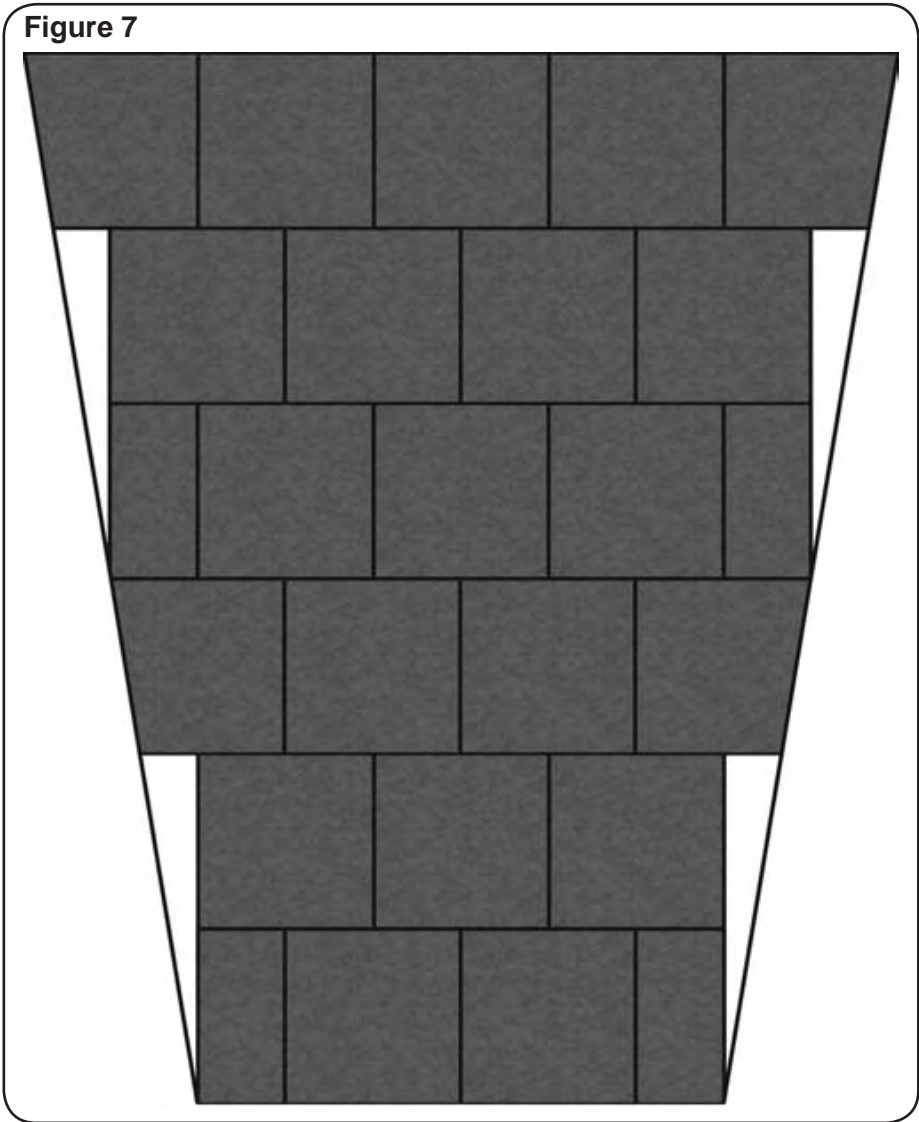
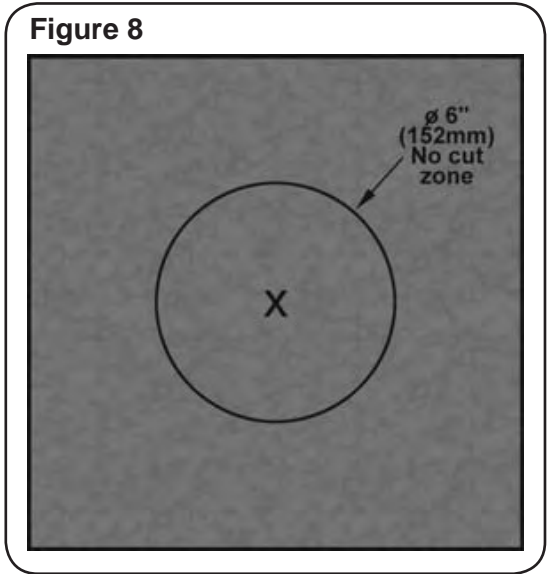

Figure 8



Largest Selection of
Conveyor Belt Cleaner
Replacement Blades



The Worlds Best Conveyor
Belt Cleaning Systems

Eraser™
Conveyor Cleaners

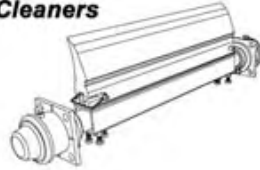

The Most Complete Line
of Conveyor Support Systems



Impact - Slide - Roll & Slide

Also Available From:



Classifier Shoes
Screen Deck Accessories
Belt Skirting
Snap-Loc Dust Seal
Modular Wear Liners
Wear Resistant Sheets
Concrete Mixer Lining Systems